

## Features

- ◆ Non-magnetic substances are used to reduce magnetic distortion and to obtain higher sound quality than general metal oxide film resistors.
- ◆ Resistor film is made of oxide metal such as tin oxide and shows anti-combustion characteristics.
- ◆ Flame retardant coating
- ◆ RoHS Compliant

## Type Designation

AMRA 2 F S 103 J L  
 ① ② ③ ④ ⑤ ⑥ ⑦

①	Product Code		
②	Power Rating(W)		
③	Flame retardant insulation coating		
④	Characteristics	S	Small size
⑤	Nominal Resistans(Ω)	3 Figure Mark E-12 Series	
⑥	Resistance Tolerance	J	± 5 %
⑦	Taping&Forming	L	Forming
		T	Taping

## Construction and Materials

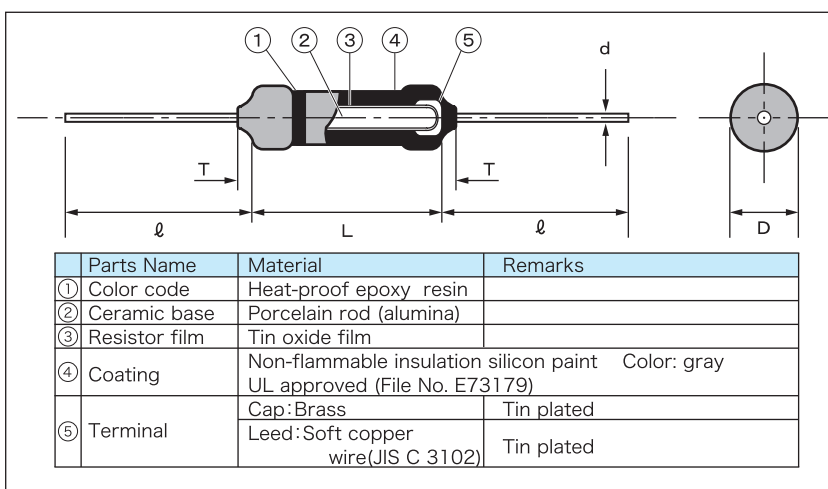

## Derating Curve

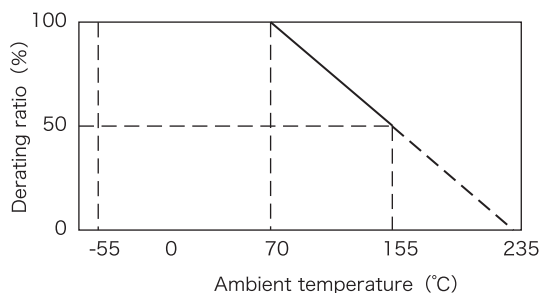

## Dimensions

(mm)

Type	L	D	ℓ	d	T
1/2FS	6.3±0.5	2.5±0.4	20<	0.6	2.0>
1FS	9.0±1.0	3.1±0.8	20<	0.7	2.0>
2FS	11.0±1.0	4.0±0.8	20<	0.8	2.0>
5FS	24.5±1.0	8.5±1.0	20<	0.8	4.0>

## Rating

Type	Characteristics	Power Rating	Max Working Voltage	Max Overload Voltage	Max intermittent Overload Voltage	Dielectric with-standing Voltage	Resistance Range	Rated Ambient Temp	Operating Temp Range
		(W)	(V)	(V)	(V)	(V)	(Ω)	(°C)	(°C)
1/2FS	S	0.5	250	400	500	250	0.1 ~ 150K	+70°C	-55~+155°C
1FS		1	350	600	750	350	0.1 ~ 270K		
2FS		2	350	600	750	350	0.1 ~ 470K		
5FS		5	500	800	1500	500	0.5 ~ 560K		

The rated voltage shall be calculated by square root( $E \times R$ )

When this value exceeds a maximum working voltage given in table, this maximum working voltage shall taken the rated voltage.

Where, E; rated voltage(V) P; rated dissipation(W) R; nominal resistance value(Ω)